

Report Documentation Page

Form Approved
OMB No. 0704-0188

Public reporting burden for the collection of information is estimated to average 1 hour per response, including the time for reviewing instructions, searching existing data sources, gathering and maintaining the data needed, and completing and reviewing the collection of information. Send comments regarding this burden estimate or any other aspect of this collection of information, including suggestions for reducing this burden, to Washington Headquarters Services, Directorate for Information Operations and Reports, 1215 Jefferson Davis Highway, Suite 1204, Arlington VA 22202-4302. Respondents should be aware that notwithstanding any other provision of law, no person shall be subject to a penalty for failing to comply with a collection of information if it does not display a currently valid OMB control number.

1. REPORT DATE 2006		2. REPORT TYPE		3. DATES COVERED 00-00-2006 to 00-00-2006	
4. TITLE AND SUBTITLE Overview of the GPS M Code Signal				5a. CONTRACT NUMBER	
				5b. GRANT NUMBER	
				5c. PROGRAM ELEMENT NUMBER	
6. AUTHOR(S)				5d. PROJECT NUMBER	
				5e. TASK NUMBER	
				5f. WORK UNIT NUMBER	
7. PERFORMING ORGANIZATION NAME(S) AND ADDRESS(ES) MITRE Corporation, 202 Burlington Road, Bedford, MA, 01730-1420				8. PERFORMING ORGANIZATION REPORT NUMBER	
9. SPONSORING/MONITORING AGENCY NAME(S) AND ADDRESS(ES)				10. SPONSOR/MONITOR'S ACRONYM(S)	
				11. SPONSOR/MONITOR'S REPORT NUMBER(S)	
12. DISTRIBUTION/AVAILABILITY STATEMENT Approved for public release; distribution unlimited					
13. SUPPLEMENTARY NOTES The original document contains color images.					
14. ABSTRACT					
15. SUBJECT TERMS					
16. SECURITY CLASSIFICATION OF:			17. LIMITATION OF ABSTRACT	18. NUMBER OF PAGES 8	19a. NAME OF RESPONSIBLE PERSON
a. REPORT unclassified	b. ABSTRACT unclassified	c. THIS PAGE unclassified			

Overview of the GPS M Code Signal

Capt. Brian C. Barker, *US Air Force, GPS Joint Program Office*
John W. Betz, *The MITRE Corporation*
John E. Clark, *The Aerospace Corporation*
Jeffrey T. Correia, *The MITRE Corporation*
James T. Gillis, *The Aerospace Corporation*
Steven Lazar, *The Aerospace Corporation*
Lt. Kaysi A. Rehorn, *US Air Force, GPS Joint Program Office*
John R. Straton, III, *ARINC*

BIOGRAPHIES

Capt. Brian C. Barker received a B.S. in Electrical Engineering from the Georgia Institute of Technology. In his initial assignment to the 2d Space Operations Squadron at Schriever Air Force Base, Colorado, he was a Navigation Payload operator and the GPS Tactics and Navigation Payload Analyst, where he was responsible for monitoring signals in space, resolving satellite and ground system anomalies, designing concepts and operational procedures for GPS warfighting tactics and the GPS User Support System, and directing satellite maintenance actions. In March 1999, Capt. Barker transferred to the GPS Joint Program Office (JPO) in the Space and Missile Systems Center at Los Angeles Air Force Base, where he leads the GPS Modernization Signal Design Team (GMSDT) designing the new military signal, and directs development of a new security architecture for military GPS.

John W. Betz is a Consulting Engineer at The MITRE Corporation. He received a Ph.D. in Electrical and Computer Engineering from Northeastern University. His work involves development and analysis of signal processing for communications, navigation, radar, and other applications. During 1998 and 1999, Dr. Betz led GMSDT's Modulation and Acquisition Design subteam.

John Clark received a B.S. in Physics and a M.S. in Engineering from the University of California at Los Angeles. He has over 20 years of experience at The Aerospace Corporation. Since 1985, he has advised the GPS Joint Program Office and US government on the engineering, management, and use of GPS.

Jeffrey T. Correia received the BSEE and MSEE degrees from Northeastern University in 1988 and 1990 respectively. He has been with The MITRE Corporation in Bedford MA since 1990 where he has worked on waveform development and antijam signal processing for spread spectrum based communications systems. Most recently he has been working on the modernization of the GPS signal for the military. Mr. Correia was appointed by the GPS

JPO to lead the GMSDT's subteam responsible for preliminary verification of the M code signal candidates.

James T. Gillis is a Senior Project Engineer in the Global Position System Division, Military Utilization Directorate, of the Aerospace Corporation. He received a BS in System Science and Applied Mathematics from Washington University in 1979, and a Ph.D. in Electrical Engineering from the University of California at Los Angeles in 1988. He has been a member of the GPS Selective Availability and Anti Spoofing Module team, and was co-chair of the GMSDT's Security Design subteam.

Mr. Steve Lazar received his B.Sc. and M.Sc. from the University of California at Los Angeles. Currently, he is a senior project leader with over 20 years of experience at The Aerospace Corporation. He has spent the last 9 years supporting the GPS JPO and the Federal Aviation Administration, with responsibilities that include signal design and spectrum management.

Lt. Kaysi A. Rehorn graduated from the University of Colorado with a Bachelor of Science degree in Aerospace Engineering. Her systems engineering work at the GPS JPO has ranged from spectrum allocation to developing navigation warfare strategies and technologies. From October 1998 to June 1999, Lt. Rehorn was lead engineer responsible for M code signal development; she now leads the acquisition and engineering efforts implementing Modernization on the Block IIF satellites. She is a Masters of Business Administration student at Webster University.

John R. Straton, III is a Principal Engineer with ARINC Incorporated in El Segundo, California. He received his BS in Astronautical Engineering from the United States Air Force Academy. He has over 15 years of experience in GPS, including five years assignment to the GPS Operational Control System as Instructor for Navigation Payload Operations. Since 1989, Mr. Straton has supported the Systems Engineering Directorate of the GPS JPO. During 1998 and 1999, he led the GMSDT's subteam for the development and design of the navigation data message.

ABSTRACT

Over the past year, the GPS Military Signal Design Team (GMSDT), led by the GPS Joint Program Office (JPO), has produced a recommended design of the new military signal for the L1 and L2 bands. This paper synthesizes the resulting M code signal design, which is to be implemented in modernized satellites and in a new generation of receivers. The paper summarizes the history that led to GPS Modernization with a new military signal on L1 and L2. After an overview of the M code signal design, the paper describes the modulation design, along with aspects of the design for signal acquisition and the data message. It also outlines some of the aspects of implementing M code signal transmission on modernized satellites, and M code signal reception in a new generation of User Equipment. Plans for refinement and further verification of the design are outlined.

INTRODUCTION

The motivations for GPS Modernization, as an essential part of GPS navigation warfare (NAVWAR), have been aptly described summarized in [1] and its references. The objectives of the modernized military signal in the context of NAVWAR are protecting military use of GPS by the US and its allies, preventing hostile use of GPS, while preserving the peaceful use of the civil radionavigation service. Furthermore, Modernization entails improving performance of GPS service for both civilian and military users, while recognizing that the threat against the military user may continue to increase. Thus, the job of the GPS Modernization Signal Design Team (GMSDT) was to design a signal that provides functions, performance, and flexibility for an enhanced military radionavigation service, while ensuring that current military and civilian receivers continue to operate with the same or better performance as they do today.

While some of the proposed approaches during early consideration of GPS Modernization involved new frequencies other than the existing carriers at L1 (1575.42 MHz) and L2 (1227.6 MHz), the technical and regulatory benefits of operating within the existing radionavigation satellite service (RNSS) bands, coupled with the scarcity of L-band or other spectrum, constrained any new military signal to the currently registered GPS bands. The challenge was to identify designs for the combined architecture of civil and military signals that would fit within the bands but have sufficient isolation to prevent mutual interference. Since the U.S. is intending to discontinue the use of Selective Availability, C/A on L1 will be even more important for civilian and aviation use. With the Vice Presidential announcement in March 1998, the C/A code signal will be transmitted on L2 as well. In addition, a new civil signal is planned at 1176.45 MHz [2].

During 1997 and 1998, the JPO led an initial investigation into the design of a new military signal for use on L1 and L2. Several fundamentally different signal architectures were considered, along with various modulation designs and alternatives for transmitting the new signal from space vehicles. As described in [1] and its references, this work culminated in the conclusion that frequency reuse was feasible, that the signal architecture on both L1 and L2 should include C/A code signals in the center of each band for civil use while retaining the Y code signal, and that the new military signal should use a "split spectrum" modulation that placed most of its power near the edges of the allocated bands. Further, the results showed that an offset carrier modulation [3] was the best option, and that there were distinct advantages for transmitting the new M code signal through a separate RF chain and antenna aperture on the spacecraft.

Later in 1998, the JPO formed the GMSDT to examine further the modulation design, while designing other components of the M code signal including the approach for signal acquisition, a new data message format, and a new security architecture. Thorough examination of many options, coupled with extensive analysis and experimentation (some of which is documented in references of this paper) has led to completion of most of the design. The resulting design recommendation was briefed by the JPO to the GPS Independent Review Team (IRT) in August 1999. The IRT's approval of the design recommendation, with praise for the design and evaluation process that led to the recommendation, clears the way for testing and documentation of the signal design details, while design and development begin for modernized space vehicles and M code signal receivers. The resulting signal architecture is shown in Figure 1.

This paper describes the M code signal design that has been selected. It emphasizes not the process that led to the design, but rather the resulting design itself. The next section summarizes the M code signal design. Subsequent sections provide overviews, in turn, of the modulation design, the acquisition design, and the data message design. Important aspects of implementing the new signal on space vehicles and in user equipment are summarized.

OVERVIEW OF THE M CODE SIGNAL DESIGN

The M code signal design needed to provide better jamming resistance than the Y code signal, primarily through enabling transmission at much higher power without interference with C/A code or Y code receivers. The M code signal also needed to be compatible with prevention jamming against enemy use of GPS [1]. The design should provide more robust signal acquisition than is achieved today, while offering better security in terms of exclusivity, authentication, and confidentiality, along with streamlined key distribution. In other aspects, the M code signal should

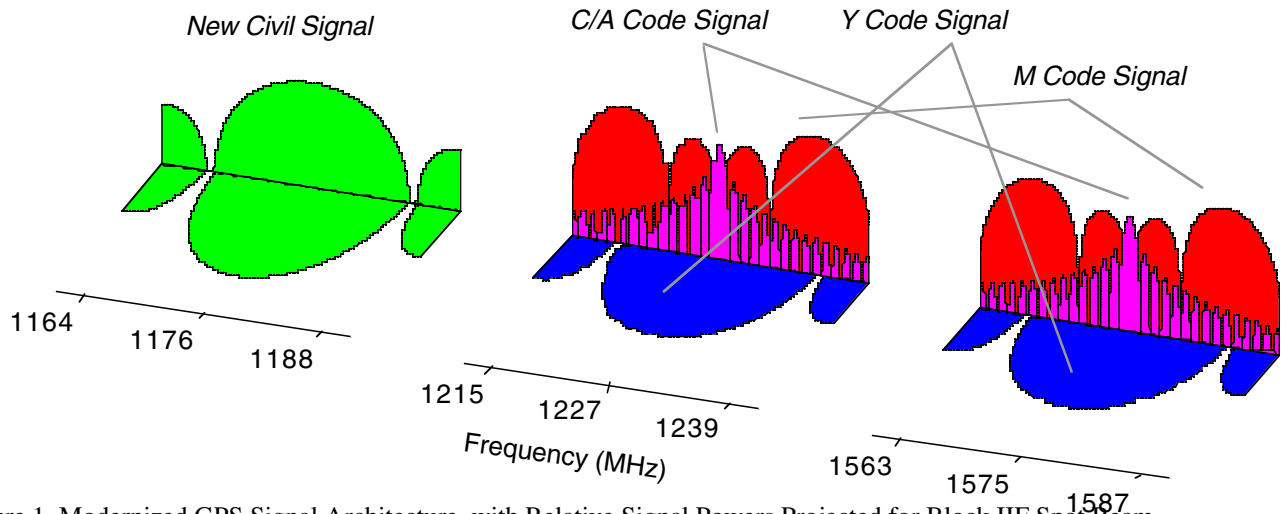

Figure 1. Modernized GPS Signal Architecture, with Relative Signal Powers Projected for Block IIF Spot Beam

provide at least comparable performance to the Y code signal, and preferably better performance. It also should provide more flexibility than the Y code signal offers.

While providing these benefits, the M code signal must coexist with current signals on L1 and L2, not interfering with current or future civilian or military user equipment. Further, it must be simple and low-risk to implement both on space vehicles and in future user equipment. In particular, since transmit power on the spacecraft is both limited and in high demand for many applications, the M code signal design—and the overall signal architecture—must be as power efficient as possible.

The recommended M code design satisfies these needs within the constraints. The modulation of the M code signal is a binary offset carrier signal with subcarrier frequency 10.23 MHz and spreading code rate of 5.115 M spreading bits per second, denoted a BOC(10.23,5.115) (abbreviated as BOC(10,5)) modulation. Spreading and data modulations employ biphase modulation, so that the signal occupies one phase quadrature channel of the carrier. The spreading code is a pseudorandom bit stream from a signal protection algorithm, having no apparent structure or period.

The baseline acquisition approach uses direct acquisition of the M code navigation signal, obtaining processing gain through the use of large correlator circuits in the user equipment. Several acquisition aids are still being considered to supplement direct acquisition.

The data message provides considerable flexibility in content, structure, and bit rate, combined with strong forward error control. Various aspects of the data message can be configured differently on different orbital planes, different individual satellites, and even different carriers on a given satellite, allowing a considerable amount of operational flexibility.

The M code signal's security design is based on next generation cryptography and other aspects, including a new keying architecture.

As enabled by the satellite's RF and antenna designs, a given satellite may transmit two different M code signals at each carrier frequency (but physically different carriers). This allows for a lower power signal with wide enough angular coverage for earth and space users (termed the earth coverage signal), in conjunction with a higher power signal transmitted in a spot beam (the spot signal) for greater anti-jam (AJ) from space in a localized region. These two M code signals, while transmitted from the same satellite at the same carrier frequency, are distinct signals with different carriers, spreading codes, data messages, and other aspects.

M CODE SIGNAL MODULATION DESIGN

The BOC(10,5) modulation uses a 10.23 MHz square wave subcarrier modulated by spreading code bits at a rate of 5.115 M bit/s; the spreading code transitions are aligned with transitions of the square wave subcarrier. While details of BOC modulations are provided in [3], characteristics of the BOC(10,5) modulation are summarized here.

An example of the resulting biphase baseband waveform is provided in Figure 2. An essential aspect of this waveform is that it has constant modulus, which contributes to efficient implementation, even while it provides the spectrum shaping needed for frequency reuse. Each bit of the spreading sequence is applied to two complete cycles of a square wave, which is equivalent to a direct sequence modulation using the unconventional spreading symbol illustrated in Figure 3.

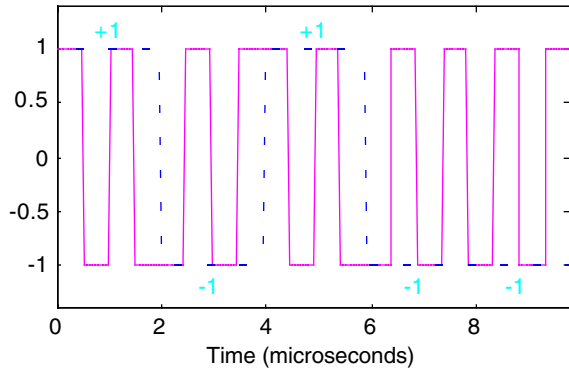

Figure 2. Example Segment of BOC(10,5) Baseband Signal (Solid Line), with Spreading Code Sequence +1, -1, +1, -1, -1 (Dashed Line)

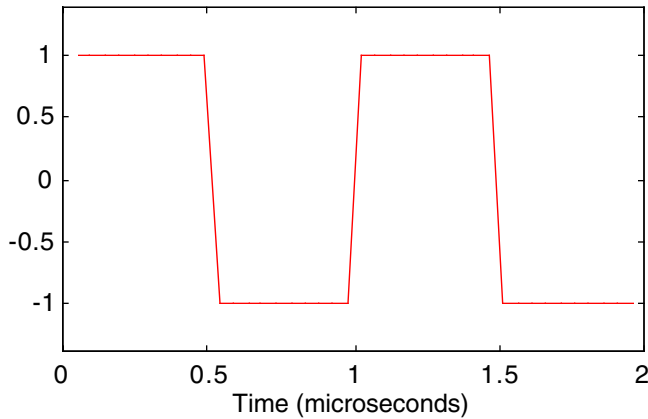

Figure 3. Spreading Symbol for BOC(10,5) Modulation

Since the spreading symbol has average value of zero, its spectrum has a null at band center. Also, since the dominant variations in the spreading symbol occur at a higher rate than the spreading code is applied, most of the BOC(10,5)'s power occurs at frequencies higher than the spreading code rate. Its power spectral density is given by [3]

$$G_{\text{BOC}(f_s, f_c)}(f) = f_c \left(\frac{\sin\left(\frac{\pi f}{2f_s}\right) \sin\left(\frac{\pi f}{f_c}\right)}{\pi f \cos\left(\frac{\pi f}{2f_s}\right)} \right)^2, \quad (1)$$

$$f_s = 10.23 \times 10^6, f_c = 5.115 \times 10^6,$$

and illustrated in Figure 4, where its spectrum is compared to that of the C/A code signal and the Y code signal, with all signals having 1 W power. More than 75% of the M code signal power is within the 24 MHz bandwidth registered for GPS.

The autocorrelation function of BOC(10,5), strictly bandlimited to a complex bandwidth of 24 MHz, is illustrated in Figure 5. The sharp main peak enables highly accurate code tracking [4], and good multipath resolution. In white noise, the RMS pseudorange error of the M code signal is approximately one-third that of the Y code signal, potentially providing better navigation performance.

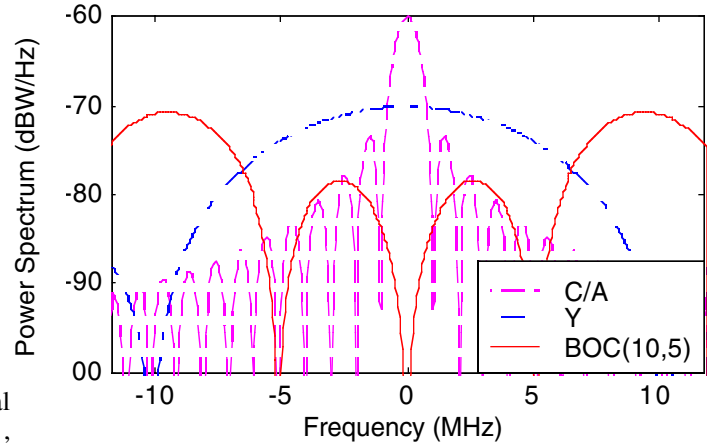

Figure 4. Power Spectral Densities, in dBW/Hz, of Baseband C/A Code, Y Code, and M Code Signals, at 1 W

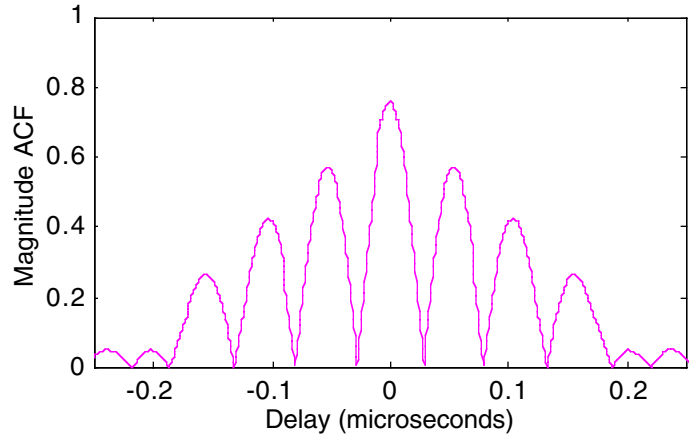

Figure 5. Magnitude Autocorrelation Function of M Code Signal Bandlimited to Complex Bandwidth of 24 MHz, Normalized to Power in Infinite Bandwidth

Extensive analysis based on the theory presented in [5] and confirmed by hardware measurements, shows that AJ performance of the BOC(10,5) modulation is comparable to that of other modulations considered [6] and to Y code at the same power level. Since the BOC(10,5) modulation's spectrum is distinct from that of the Y and C/A code signals, the BOC(10,5) modulation can be received at high power levels without degrading the performance of Y code receivers or C/A code receivers [7]. The BOC(10,5) modulation is also insensitive to jamming that might be directed against the C/A code signal. Thus, the BOC(10,5) modulation satisfies all requirements for the M code signal.

The binary sequence used to spread the BOC(10,5) modulation has no discernible structure. Consequently, there is neither need nor opportunity to carefully design the spreading code, as was done for the C/A code signal and the new civil signal on L5.

SIGNAL ACQUISITION DESIGN

The M code signal has been designed for autonomous acquisition, so that a receiver will be able to acquire the M

code signal without access to C/A code or Y code signals. Many options have been considered to enable robust acquisition of the M code signal in jamming, when the initial time uncertainty is on the order of seconds. The baseline M code signal design recommends that receivers needing to operate in heavy jamming perform direct acquisition of the M code navigation signal, using a processing architecture that provides large processing gain. This approach, analyzed in [8], allows acquisition processing to make use of all the power transmitted on a carrier, while being immune to advanced jamming techniques. Continuing growth in semiconductor technology is projected to enable this direct acquisition circuitry in the time frame of interest.

In order to provide rapid acquisition even with large initial uncertainties in time, several different acquisition aids are being assessed.

Whenever the BOC(10,5) modulation is being acquired (either the navigation signal directly, an acquisition aid, or a separate acquisition signal using the BOC(10,5) modulation) receiver processing can take advantage of the modulation's unique sideband structure. In particular, acquisition processing is simplified considerably in forming acquisition test statistics by noncoherently combining results from processing the upper and lower sidebands separately [8]. This approach, portrayed in Figure 6, allows the acquisition search to proceed at a time granularity commensurate with the spreading code rate, rather than the (faster) subcarrier rate. The computational simplification outweighs the slight performance loss from the noncoherent combination of results from the upper and lower sidebands.

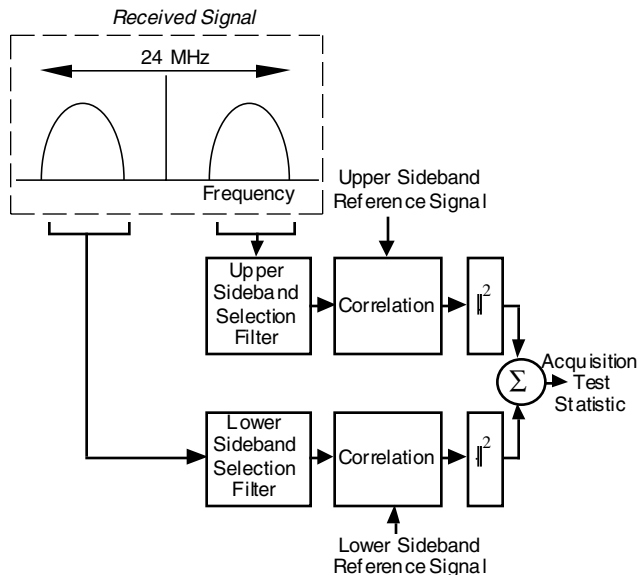

Figure 6. Sideband Processing for Signal Acquisition

M CODE SIGNAL DATA MESSAGE DESIGN

The M-code signal data message structure was designed to meet the following set of criteria:

- Provide flexibility of format, control and content;
- Improve the performance of all key parameters (e.g., Better error rates and reduced data collection times);
- Improve the system's data security and integrity;
- Enable enhancements to the system's security architecture and key management infrastructure; and
- Enable future adaptations to the GPS data message as military applications, technology and mission requirements evolve.

More detailed and quantitative versions of these criteria were employed during the trade study performed by the Data Message Subteam (DMS)—a subgroup of the GMSDT—to arrive at the proposed military navigation (MNAV) data message design. The trade study approach is summarized in Figure 7.

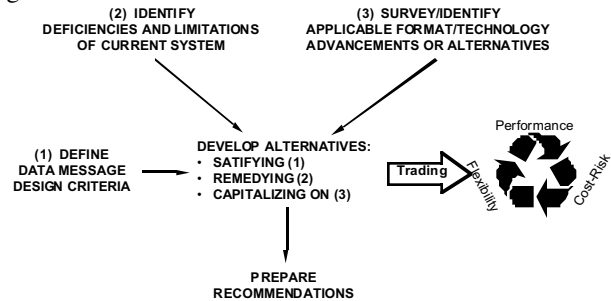

Figure 7. DMS Trade Study Approach

The trade study was necessarily constrained by two core characteristics of military GPS. The first is that GPS is primarily a radionavigation service for the U.S. and allied forces, as well as the civilian community. The DMS dismissed alternatives that diminished the ability of GPS to continue to support that key mission. For example, data collection times could be dramatically reduced by implementing very high speed data rates. However, the penalty paid in terms of AJ performance outweigh the potential benefit that such high data rates might otherwise provide. The second constraint is the fact that GPS is an existing system, with an enormous installed user base. Alternatives significantly impacting user concept of operations (CONOPS) or necessitating costly integration were likewise deemed incompatible with the overall objective of military GPS modernization.

Keeping in mind the constraints just mentioned, the DMS nevertheless sought to design a new data message structure with the flexibility and robustness to satisfy current requirements, while retaining the capacity to satisfy future mission needs. Early in the trade study, DMS investigators recognized the opportunity represented by the ubiquity of GPS in DoD weapons systems. What other radio is fielded on everything from submarines to soldiers, from UAVs to 5-inch artillery rounds? The leverage such a standardized radio provides—albeit one-way—in terms of force integration is immense. Accordingly, the DMS was keenly motivated to develop a new data message permitting future weapons systems integrators to utilize their GPS user

equipment (UE) for applications which haven't even been identified yet.

Briefly, the proposed MNAV data message design replaces the use of frames and subframes, as in the current NAV data message, with a packetized Message-based communications protocol. The decision to dispense with a periodically repeating fixed format was motivated by the need to improve the ability of the system to accommodate new data contents.

Control of the MNAV data message content has also been dramatically improved. Each operational M-code SV may transmit different data message content on L1 and L2 channels, and at different data rates. Similarly, the data message content from different space vehicles (SVs) may differ. This flexibility permits system operators to configure the Space Segment (SS) in a variety of space-division or frequency-division modes to respond to a wide range of operational needs and circumstances.

The proposed MNAV format also includes provisions for improved error control, including a modern parity algorithm and forward error control (FEC). The MNAV format will also include provisions for military considerations such as burst-error protection, data message authentication and validation, and encryption.

MNAV design is progressing rapidly. Key elements have yet to be defined, but most of these elements are design details that will not likely affect the overall MNAV architecture. As it stands, the proposed MNAV design promises to provide enhanced AJ capability, expanded data bandwidth capacity, and improved signal security to GPS military users for decades to come.

M CODE SIGNAL IMPLEMENTATION ON SPACE VEHICLES

The DoD plans to modernize some Block IIF space vehicles (SVs) for transmission of the M code signal. This section summarizes some of the satellite design aspects and the resulting signal characteristics. All of the numerical values provided are nominal, for illustrative purposes only, since detailed specifications and designs are not yet finalized.

Fully modernized Block IIF satellites will transmit two distinct M code signals on both L1 and L2. The earth coverage signal will be received at a nominal power level of -158 dBW over the entire surface of the earth viewed by the satellite, and extending into space. The spot beam signal will be received at a nominal power level of -138 dBW. The earth coverage signal and spot beam signal have different spreading sequences, can have different data messages, and are treated by a receiver as distinct signals, analogous to signals from different satellites. Current plans are for nominal received power levels on both L1 and L2 to be -157 dBW for the C/A code signal and -160 dBW for the Y code signal. The nominal received power level of the civil signal on L5 will be -154 dBW.

The baseline design for the modernized Block IIF involves three RF chains and three apertures for navigation signals. The existing RF chain and antenna are essentially unmodified, and used to transmit C/A code and Y code in phase quadrature on L1 and L2, consistent with the pre-modernization design for Block IIF satellites. The new civil signal on L5 is also power combined with these signals and transmitted from the same antenna. A new RF chain generates the earth coverage signal, transmitted from a new antenna that is also mounted on the satellite body. An additional RF chain generates the spot beam signal when it is turned on. The spot beam antenna is a parabolic dish extended from the satellite body.

Supplying the additional power for the new signals involves additional solar panels. New baseband circuitry is added to generate the data messages and the spreading sequences for M code signals and the new civil signal. RF circuitry and power amplifiers are added for the new signals, along with the antennas mentioned above. Crosslinks and other supporting functions are also enhanced to provide additional functionality needed for the M code signal.

M CODE SIGNAL IMPLEMENTATION IN UE

This section emphasizes the aspects of M code receiver design that either differ from a typical Y code receiver, or represent enhancements to today's military receivers.

A high-level receiver architecture is shown in Figure 8. In the front end of a receiver, the signals received at L1 and L2 are translated to an intermediate frequency, where they are digitized. Typically this downconversion is done in one or two stages. M code receivers may use frequency plans that are similar to those of current military receivers. In fact, the baseline M code receiver architectures under consideration also provide for reception of C/A code and Y code, although this is not required.

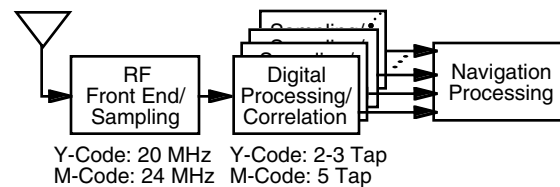

Figure 8. Receiver Architecture

As shown in Figure 4, the spectrum of the M-code signal extends to the edges of the 24 MHz band—wider than the nominal 20 MHz bandwidth of Y code. Increased reliance on the signal near band edge requires antennas and front-end filters with wider bandwidths and less distortion of gain and phase, while still rejecting out-of-band interference. Since analog filters introduce phase distortion near the transition region of the filter, the bandwidth of selection filters may be somewhat wider than 24 MHz in some applications. Subsequent digital filtering can then reduce the bandwidth of the sampled signal, attenuating the band edges without phase distortion. Since such an implementation requires

higher sampling rates and subsequent signal processing for decimation, other alternatives may be preferred in some applications, depending on considerations such as the level of technology available, the degree of performance needed, antenna constraints, and issues of size, weight, and power.

Specialized code tracking approaches can take advantage of the multimodal correlation function shown in Figure 5. The narrow center peak offers very accurate code tracking, while additional processing ensures that the code tracking loop tracks the correct peak. One method for accomplishing this involves very-early/very-late processing described in [10] as “bump jumping”. The code tracking loop architecture for this scheme is shown in Figure 9.

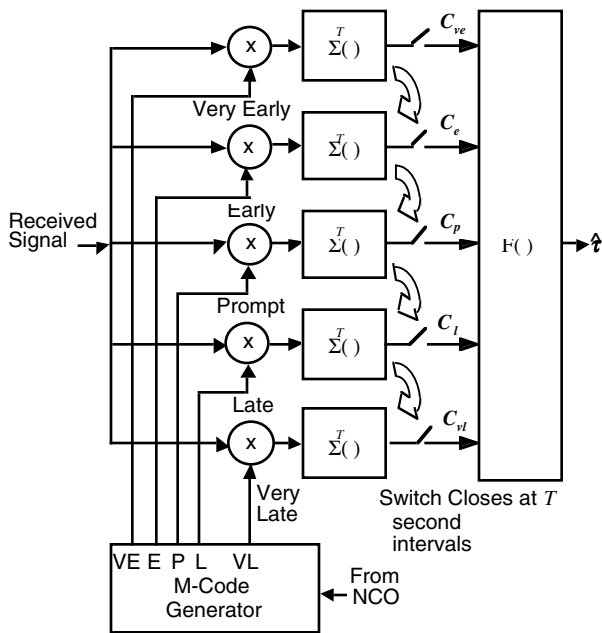

Figure 9. Code Tracking Loop Architecture for Very-Early/Very-Late Processing

The functions in Figure 9 involving early, prompt, and late taps represents typical minimum processing used today in the code tracking loop of a typical military receiver. The additional very-early and very-late correlator taps sample the adjacent peaks of the M-code correlation function, ensuring that the prompt reference is aligned with the main peak of the correlation function, and not a secondary peak. If either the very-early or the very-late tap repeatedly indicates a greater magnitude than its counterpart and the prompt signal, this indicates a lock on the wrong peak, and the phase of the replicated code is accordingly adjusted by a step change. Note also that the multi-lobed peak of the M-code autocorrelation function is compatible with techniques such as extended range correlation that are employed in current military receivers.

Carrier tracking of the M-code signal is done identically as in conventional receivers, operating on the “Prompt” output of Figure 9. While data demodulation is also analogous to

that performed in current receivers, widely-used Viterbi decoding is employed.

Most other aspects of the receiver architecture for M code receiver processing remain unchanged from the Y code receiver, although the details are different.

Design of signal acquisition processing has emphasized architectures for direct acquisition of the M code signal, and several alternative architectures have been studied. Each offers different advantages in terms of AJ capability, time to acquire, circuit clock speed, circuit complexity, and compatibility with acquiring punctured acquisition designs. Some architectures draw on technology being developed for direct acquisition of the Y code signal, while others use novel approaches that draw on advances in integrated circuit technology. Various receiver processing approaches are also being considered in conjunction with proposed concepts for dedicated acquisition signals.

SUMMARY AND FUTURE PLANS

The M code signal design forms the core of the military GPS utility for decades to come. The innovative BOC modulation design allows continued military use of existing GPS frequencies while enabling NAVWAR prevention efforts. It ensures backward compatibility with existing military and civilian GPS receivers while protecting the military utility of GPS through high power transmissions for improved jamming resistance. The BOC modulation also allows receivers to exploit its wideband characteristics. Autonomous acquisition of the M code signal using direct acquisition technology offers increased robustness. The powerful new data message format significantly improves key performance measures of the GPS data message, reduces inefficiencies that exist in the current format, and provides the flexibility to manage the GPS signal-in-space data contents to address a wide range of current and future operational needs. It enables an over-the-air-rekey capability for the warfighter, while providing considerable flexibility to accommodate growth and changes in GPS operational needs. New security features provide improved security with better ease of use.

Even at the earth coverage power level, the M code signal offers comparable jamming resistance to the Y code signal, more robust acquisition, much greater immunity to prevention jamming, better security features, and an improved data message.

The in-depth design and evaluation process used by the GMSDT led to objective design decisions even though some of the requirements were subjective. New theory was developed to design code tracking loops for the novel BOC modulations, and new receiver processing approaches were developed and demonstrated to take advantage of BOC signals’ unique characteristics. This new theory also predicted effects of jamming and interference on code tracking accuracy. A first-of-its-kind hardware suite [11] was

developed to perform real-time, full-bandwidth, RF processing of the novel signals. Extensive testing using this hardware reduced risk by proving that these signals can be used for navigation and timing. The hardware also provides instrumentation-quality measurements of critical performance parameters, agreeing remarkably with theoretical predictions.

Detailed design is continuing on several aspects of the M code signal, and the completed design is being documented in Interface Control Documents and other specifications.

Planning for signal verification is also continuing. An evolutionary plan is being assembled, starting with laboratory testing, moving to inverted range testing, and then to final testing using the signals from the first modernized satellites. While there currently is transmit equipment that generates the M code signal's modulation, and receive equipment that performs basic signal tracking functions, both will be enhanced. The transmit equipment will be upgraded to provide M code signals simultaneously on L1 and L2, to use the appropriate spreading sequences, and to include the data message. The receive equipment will perform autonomous signal acquisition, process all satellites in view on both L1 and L2, use the appropriate spreading sequences and data message, and develop navigation solutions. Verification work also will include additional testing of the M code signal's backward compatibility with receivers for the C/A code signal, the Y code signal, and WAAS.

ACKNOWLEDGMENTS

The authors express their appreciation to many members of the GMSDT whose innovative suggestions and hard work contributed to the design of the M code signal. We especially thank Paul S. Timmel, National Security Agency, who co-chaired the GMSDT's Security Design subteam. The Aerospace Corporation's work was supported by Air Force contract F04701-93-C-0094. ARINC's work was supported by Air Force contract F04701-95-D-0013/SSASII-SC-95-045. The MITRE Corporation's work was supported by Air Force contract F19628-99-C-001.

REFERENCES

1. D. J. Lucia, J. M. Anderson, "Analysis and Recommendation for the Reuse of the L1 and L2 GPS Spectrum," *Proceedings of ION GPS-98*, Institute of Navigation, September 1998.
2. J. J. Spilker and A. J. Van Dierendonck "Proposed New Civil GPS Signal at 1176.45 MHz," *Proceedings of ION GPS-99*, Institute of Navigation, September 1999.
3. J. W. Betz, "The Offset Carrier Modulation for GPS Modernization," *Proceedings of ION 1999 National Technical Meeting*, Institute of Navigation, January 1999.
4. J. W. Betz and J. T. Correia, "Initial Results in Design and Performance of Receivers for the M Code Signal," *Proceedings of ION 2000 National Technical Meeting*, Institute of Navigation, January 2000.
5. J. W. Betz, "Effect of Narrowband Interference on GPS Code Tracking Accuracy," *Proceedings of ION 2000 National Technical Meeting*, Institute of Navigation, January 2000.
6. J. W. Betz, "Effect of Jamming on GPS M Code Signal SNIR and Code Tracking Accuracy," *Proceedings of ION 2000 National Technical Meeting*, Institute of Navigation, January 2000.
7. J. W. Betz, "Analysis of M Code Interference with C/A Code Receivers," *Proceedings of ION 2000 National Technical Meeting*, Institute of Navigation, January 2000.
8. P. Fishman and J. W. Betz, "Predicting Performance of Direct Acquisition for the M Code Signal," *Proceedings of ION 2000 National Technical Meeting*, Institute of Navigation, January 2000.
9. S. C. Fisher and K. Ghassemi, "GPS IIF—The Next Generation", *Proceedings of the IEEE*, Vol. 87, No. 1, January 1999, pp. 24-47.
10. P. Fine and W. Wilson, "Tracking Algorithm for GPS Offset Carrier Signals", *Proceedings of ION 1999 National Technical Meeting*, Institute of Navigation, January 1999.
11. J. T. Correia, et al., "A Hardware Testbed for Evaluation of the GPS Modernization Modulation Candidates," *Proceedings of ION 2000 National Technical Meeting*, Institute of Navigation, January 2000.